

## DESIGN AND IMPLEMENTATION OF A THREE PHASE 6KVA AUTOMATIC PHASE SELECTOR IN A THREE PHASE SUPPLY CIRCUIT

<sup>1</sup>Lawal, Abdur-Raheem O.,<sup>2</sup>Jimoh, Adeyemi A.,<sup>3</sup>Lawal, Olatunji A.,<sup>4</sup>Tiamiyu, Ahmed. K  
Department of Electrical/Electronic Engineering, Kwara State Polytechnic, Ilorin.

### *Abstract*

*The variation in voltage level per phase in a three phase supply circuit posed challenges in industrial power system. In this regard, this project was designed and implemented to check the availability of any live phase, and connects the load to the available live phase only. This feat was achieved with microcontroller (PIC16F628). This controller continuously checks for which of the three phases is having supply at any point in time and the load is connected to an active phase relay by the controller. The relay is driven with a transistor. This project monitors the availability and level of voltage on the three phases and selects the most suitable one. The phase is switched to the output and automatically transferred to the next available phase in the event of failure of the previously selected phase through the electromechanical switches used in the circuit. If the voltage supply on all the phases is low (less than 180v) or is high (above 220V), the device will go into the delay mode until there is a phase with voltage between 180V and 220V. This device switches between phases within fraction of a second. This is required for continuous power supply to appliances and loads. An LCD (Liquid Crystal Display) is provided to display the status of the phase*

**Keywords:** *Voltage Variation, Three Phase System, Microcontroller, Electromechanical Relay, Liquid Crystal Display.*

### **1 Introduction**

All electrical networks suffer from power quality issues in varying degree, sags and surges are common but network can exhibit voltage supply irregularities, these irregularities may cause voltage imbalance. Voltage imbalance on a supply network is usually due to generation faults, unmatched impedance on transformer banks, etc. The imbalance effects are more pronounced on industry and modern house of today, because no home is said to be one without Electrical

appliances like cookers water heaters, radios, televisions, fans, water pumps etc., all of which need electricity to operate. Unfortunately, erratic public power supply in Nigeria has pushed her citizens to seek alternatives. This has resulted in individuals installing wind turbines, solar panels, generating sets and so on. In many cases, phase absence or low voltage on a phase might be responsible for poor performance of single phase appliances in homes, offices and industries. This research work comes with a design to check the availability of power supply in any phase, and transfer the load to the active or live phase only. This feat is achieved with a Microcontroller (PIC16F628). This controller continuously checks for power supply conditions of all the phases connected to it, and the controller connects the load to the active phase, using a relay which is driven by a transistor. If two or three phases are live, the load will be connected to one of the phases only and if the phase in use fails, the load will be automatically transferred to the next available phase. In the event of mains outage none of the phases is connected until mains is fully restored. An LCD (Liquid Crystal Display) is provided to display the status of the phase condition. This project uses a regulated 12V,500mA power supply; full-wave bridge rectifier was used to rectify the 220VAC output of the step down transformer to 12VDC which was filtered and fed into the microcontroller. The microcontroller used makes the circuit more intelligent while switching between phases. The system is basically designed to select between the three phases at reasonable speed, and also addresses phase imbalance with respect to loads. This means automatic switching between the three phases with a single phase output. In other words, the switching consideration demonstrates the real and practical situation for mainly domestic, commercial and small industrial loads. A manual change-over switch requires manual monitoring and switching over between phases. This method requires human presence, human effort doing the switching, and the switching time is noticeable. In the processes of manual change-over, valuable time is wasted in addition to device or machine damage from human error during the process, which could bring losses and accident.

Hospitals, industries and airports require continuous electricity. It is therefore important to design and construct an automatic phase selector device which would save time and eliminate the danger likely to be encountered during manual changing over. The system was designed to supply loads in homes and offices but not for industrial use, this is because 30Amperes relay switches were used which can only accommodate total load not above 6KVA.

## **2. Literature review**

In most developing and underdeveloped parts of the world, the supply of electricity for industrial, commercial and domestic use is highly unstable. This gives rise to the frequent use of alternative sources of power supply to meet up with the energy demands. The Automatic three phase selector automatically switches over to the alternative phases when there is a power outage. The Automatic three phase selector is a device that links the load and the three phases and relay switches. This device maintains constant power supply to the load by automatically activating the phases when there is need. To ensure the continuity of power supply, many homes, offices and industrial facilities require a steady and stable power supply, and because of the growing complexity of electrical systems it becomes imperative to give attention to supply phases reliability and stability. Over the years many approaches have been implored in selection of phases. Some of them are discussed below.

In the past the regular practice had been to manually select the required phase in a three phase system with the help of a cut off (an electrical connector devices). This is used by appropriately interconnecting end and selecting between the phases by manually plugging in to premeasured or detected voltage. This is known as the conventional approach to phase selection. Its limitations are as follows

- i. It is strenuous to operate.
- ii. It causes device to damage.
- iii. It can cause fire outbreak and/or electrocution.

The sequential logic control was used to effect the detection and control of the phase voltage whereas the measurement can be done manually or equally automated by the same sequential circuit. This approach involves an appreciable level of both automatic and manual control. Hence it is more efficient than just the manual control (Alkar & Buhur 2005). Its limitations are as follows

- i. Clock rate is determined by the slowest logic path in the circuit; hence the circuit operation is slower.
- ii. It consumes a relatively large amount of power and dissipates much heat

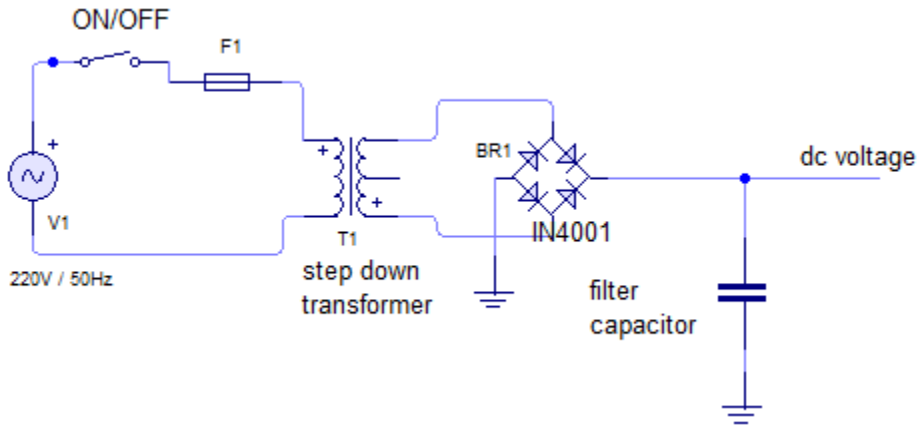
This approach uses a comparator (an operational amplifier), a device that compares two voltages and currents and outputs a digital signal indicating which is larger. It has two analog input terminals (non-inverting and inverting) and one binary digital output. When the non-inverting input ( $v_+$ ) is at higher voltage than the inverting input ( $v_-$ ), the gain of the op-amp causes the output to saturate at the highest positive voltage. When the non-inverting input ( $v_+$ ) drops below the inverting input ( $v_-$ ), the output saturates at the most negative voltage. The op-amp's output voltage is limited by the supply voltage. (Adedokun and Osunpidan 2010). Its limitations are stated below

- i. An op-amp makes a floppy comparator with propagation delays that can be as long as tens of microsecond.
- ii. Many op-amp have back to back diodes between their inputs, this diodes can cause unexpected current through inputs.
- iii. Compatibility with digital logic must be verified while using op-amp as a comparator.

In view of the limitations of the above previous works, this project implements a phase selection system that drastically reduces the shortcomings (the switching time between phases, large power consumption and heat generation). A PIC16F628 microcontroller was also incorporated to help improve the speed of automation. The system is controlled by a software program embedded in the microcontroller. This work is handy and portable compared to the bulky works done previously. It also has an important feature like the liquid crystal display (LCD) which makes the system user friendly. Economically, this project is of low cost due to the use of ICs in place of discrete components. This project uses a regulated 12V,500mA power supply; full-wave bridge rectifier was used to rectify the 220VAC output of the step down transformer to 12VDC which was filtered and fed into the microcontroller. The microcontroller used makes the circuit more intelligent while switching between phases. The system is basically designed to select between the three phases at reasonable speed, and also addresses phase imbalance with respect to loads. This means automatic switching between the three phases with a single phase output. In other words, the switching consideration demonstrates the real and practical situation for mainly domestic, commercial and small industrial loads.

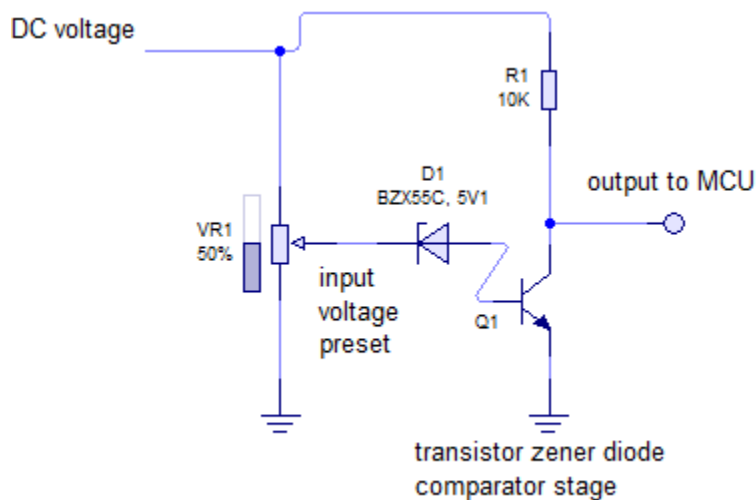
The construction of this section was carried out stage by stage with proper testing after each completion. The construction of this section include the input stage, sensing stage, processing and

logic control stage, switching stage, output stage and the casing. The input stage is basically the power supply unit. The components in this stage include a step down transformer, bridge rectifier and filter capacitor (figure 1)



**Figure 1: The input stage**

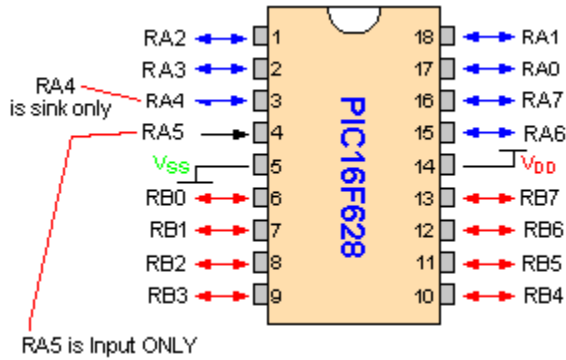
The input voltage from all the phases is step down by the step down transformer, rectified by the bridge rectifier, filtered by the capacitor and the dc output is fed to comparator’s sensing stage. The same dc voltage is used to supply the relay that controls the load. The sensing stage includes zener diode, resistor and transistor (figure 2)



**Figure 2: The sensing stage**

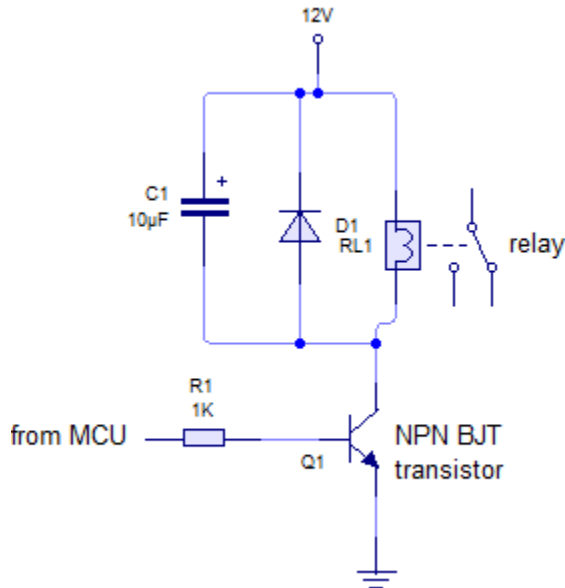
The DC voltage is compared to a reference voltage across the zener diode. The output voltage taken at the collector terminal of the transistor is fed to the microcontroller. Its output is logic 1

when the phase input voltage is less than 180V and logic 0 when the input voltage is above 180V. The processing and logic control stage monitors the input sensing stage and determines the required phase to connect to the output terminal. The components in this stage include microcontroller, voltage regulator, crystal oscillator, resistor and capacitor (figure 3)



**Figure 3: The microcontroller**

The switching stage is made up of relays, transistor and resistor. Other components include protective diode and capacitor. The microcontroller cannot drive the relay directly. The MCU drives the transistor, the transistor in turn drive the relay. The relay connects the selected phase to the output terminal of the device (figure 4)



**Figure 4: Switching stage circuit**

The output stage is made up of the LCD (Liquid Crystal Display) and the terminal where the load is connected to. The LCD display is a liquid crystal display used to display the information concerning the state of the mains power supply (figure 5). This information ranges from availability of phases to output voltage. The value of output load is determined by the maximum current rating of the relay. The maximum load this device can handle is 6KVA.



**Figure 5: LCD Display**

### 3. Methodology and calculations

Where the main supply is 220V/50Hz, the transformer used is a 220/12V according to

$$E_s/E_p = N_s/N_1 = I_p/I_s = V_s/V_p = K,$$

where  $k$  = transformation ratio.  $V_p$  = primary voltage of the transformer = 220V and

$V_s$  = secondary voltage of the transformer = 12V Hence for 220V/12V transformer,

$$K = 12/220 = 0.05455, V_{rms} = V_{max}/\sqrt{2}$$

where  $V_{max}$  is the maximum or peak voltage, hence for the secondary of the transformer and  $V_{rms}$  = 12v

$$V_{max} = 12\sqrt{2} = 16.97V$$

The type of diodes used for the full wave rectification is 1N4001, and from its datasheet, its peak current ( $I_p$ ) is 1A, maximum voltage is 50V, and the bias voltage is 0.7V. For the full-wave rectifier, the peak inverse voltage (PIV) must be within a safe limit for every components used in the circuit (Theraja and Theraja 2005) i.e. the PIV must not be more than the breakdown voltage of any of the components. Kirchoff's law implies that

$$PIV = 2V_p$$

for full wave rectifier. Hence from the above,

$$PIV = 2(16.97) = 33.94V.$$

The PIV is the maximum voltage that occurs across the rectifying diode in the reverse direction.

The 7805 voltage regulator maintains the voltage supply to the logic control section (i.e. PIC16F628) at  $5V_{dc}$ . Transistor (figure6) is selected such that

$$I_B = (V_{BB} - V_{BE}) / R_B \quad (i)$$

$$I_C = \beta(V_{BB} - V_{BE}) / R_B \quad (ii)$$

$$I_E = [V_{BB}(\beta + 1) - V_{BE}(\beta - 1)] / R_B \quad (iii)$$

Considering the collector wing;  $V_{CE}$  = voltage across collector emitter junction such that

$$V_{CE} = V_{CC} - R_C I_C \quad (iv)$$

Putting equation (ii) into equation (iv);

$$V_{CE} = V_{CC} - R_C [\beta(V_{BB} - V_{BE}) / R_B]$$

$$V_{CE} = V_{CC} - [R_C \beta(V_{BB} - V_{BE})] / R_B \quad (v)$$

For NPN transistor, the minimum proper  $V_{BE}$  is given as follows; a) When Si transistor is used,  $V_{BEQ} = 0.7V$  and b) When Ge transistor is used  $V_{BEQ} = 0.3V$  Using a silicon transistor,  $V_{BE} = 0.7V$ . Also, the voltage on any pin of the PIC16F628 with respect to  $V_{SS}$  (except for  $V_{DD}$ , /MCLR and RA4) has a maximum value of  $V_{DD} - 0.3$ . Since  $V_{DD} = 5V$ , voltage supplied to the base of the NPN transistor from the PIC16F628 (i.e.  $V_{BB}$ ) =  $5 - 0.3 = 4.7V$  The maximum output current sourced by any input/output pin = 25mA. Assume that  $\beta = 60$ , then from equation (i);

$$I_B = (V_{BB} - V_{BE}) / R_B = (4.7 - 0.7) / 1000 = 4.0mA.$$

This is still below the maximum output current of 25mA sourced by any input/output pin; hence the Microcontroller will not be overloaded. The NPN transistor in the circuit is acting like a buffer for the microcontroller, providing current and power gain. From equation (ii);

$$I_C = \beta(V_{BB} - V_{BE}) / R_B = 60(5.0 - 0.7) / 1000 = 258mA,$$

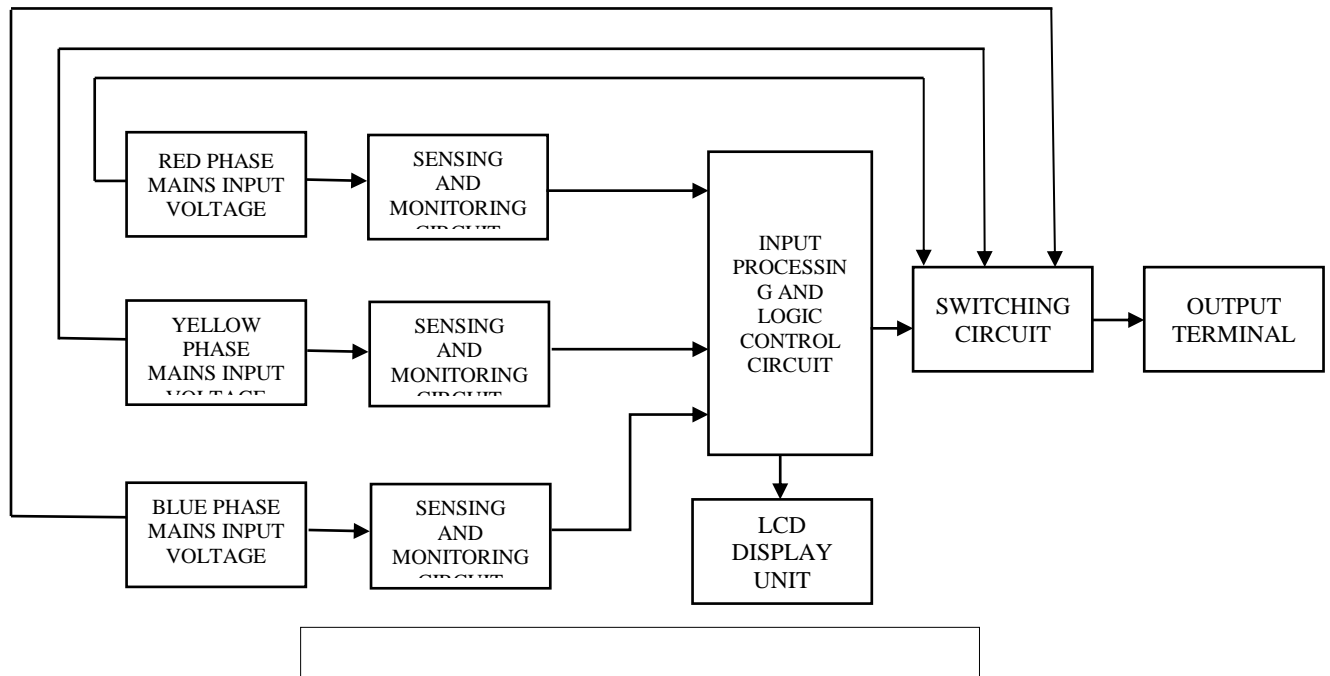
This is sufficient to power relay connected individually with a series resistor of 400Ω. From equation (iii);

$$I_E = [V_{BB}(\beta + 1) - V_{BE}(\beta - 1)] / R_B = [5.0(60 + 1) - 0.7(60 - 1)] / 1000 = 263mA$$

From equation (v);

$$V_{CE} = V_{CC} - [R_C \beta(V_{BB} - V_{BE})] / R_B = 10.69 - [400 \times 60(5.0 - 0.7)] / 1000 = 10.69 - 9.108 = 1.384V$$

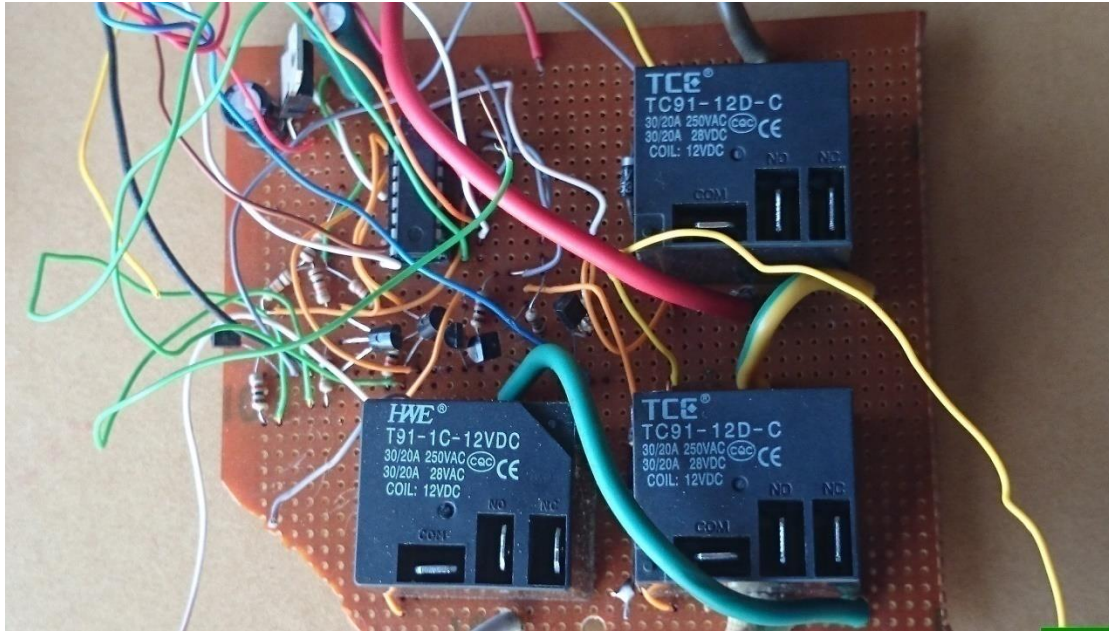




**Figure 6 Block diagram of automatic phase selector**

#### 4. Implementation and Testing

After proper design and calculations for each stage, the programmed microcontroller was tested on a breadboard with its associated circuits. Various tests were performed on all the components used to ensure that they are working properly and reliably. Having worked satisfactorily, the microcontroller and the associated components were then transferred and soldered on veroboard following light duty soldering techniques. Soldering has been firmly done to reduce loose connection and short circuit and the entire board was properly connected to accessories. All safety measures were taken to prevent electric hazard. The components (figure 7) were placed on the plain side of the board, with their leads protruding through the holes to the copper tracks on the other side of the board to make the desired connections, and any excess wire was cut off. The continuous tracks were easily and neatly cut as desired to form breaks between conductors using a cutter made for the purpose. Tracks were linked up on either side of the board using connecting wires. External wire connections to the board were made by soldering the wires through the holes and for wires too thick to pass through the holes, by soldering them directly to the copper tracks side of the board.



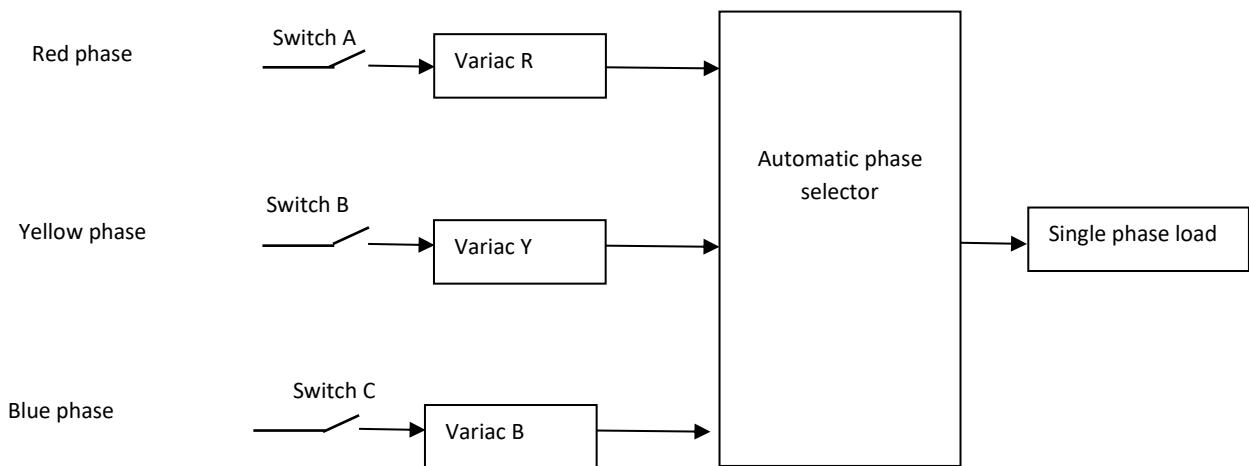
**Figure 7: Arrangement of components on Vero board**

Soldering is defined as "the joining of metals by a fusion of alloys which have relatively low melting points". In other words, soldering is more like gluing with molten metal. Soldering of the components onto a veroboard involves preparing the surface, placing the components, and then soldering the joints. Adaptable box (BS 4607), manufactured by UK-DIGNITY BRAND was used as the casing for the project (figure 8)



**Figure 8: The Project**

The system's testing was performed after thorough analysis of various sections and upon completion of circuit construction in order to test the performance of the system (figure 9). During this test the public supply was available and a 60W bulb was used as a single-phase load.



**Figure 10: Block diagram of testing arrangement**

The following steps were involved in the test evaluation of the system:

- Step 1: The system was set up as shown above, where all the voltage sources to the device's inputs were connected to variable transformers ( Variac R, Y and B)
- Step 2: Switches A, B and C was opened (OFF) to simulate phase supply outage. Also, switches A, B and C are closed (ON) to indicate phase supply availability.
- Step 3: The supplied voltage to the system inputs are varied, while the output voltages are displayed on the LCD.

## 5 Conclusion

The inputs to the device are connected to three phase power source (red, yellow and blue), with switches A,B and C to demonstrate when utility power supply is available and when it is not by switching ON and OFF. The switches were connected to three different Variacs(R, Y and B) to vary the input voltages to the device and a 60W bulb was used as a single phase load. When all the switches were OFF, indicating there is no availability of utility power supply on all the three phases, the bulb did not light up because there was no power supply to the device. Switches B and C were ON while switch A was OFF, indicating there is no power supply on the red phase. The bulb lights up through the supply from the blue phase because Variac Y (yellow phase) is below preference voltage which is 180volt.

In summary, from the result obtained, it can be seen that the device will only supply power to the load when there is availability of power supply on one or two of the phases provided the voltage on any of the phases is between 180volt and 220volt. When the same acceptable voltage is available on the two phases, say on red, and yellow phase, power is supplied to the load through the red phase because the order of preference or priority was set to be red phase, yellow phase and blue phase respectively. If voltage is lower than 180v or greater than 220volt in all the available phases, the device will switch to “delay mode” until set voltage is available.

Automatic Phase Selector using microcontroller has been designed, implemented and tested. The system operates according to the specification and quite satisfactorily. With the use of microcontroller, this device is guaranteed to work perfectly. The switching speed is fast, when compared to manual switching. This device is more reliable, is of less cost and maintenance free. Whenever there is power outage in any one or two of the three phases, it performs automatic

changeover process. Thus the system reduces stress and delay associated with manual changeover. In future, the device can be designed to accommodate starting a generator, detecting the fuel level, and stopping the generator when the mains power is restored or when fuel level is low.

## References

- Adedokun, G and Osunpidan, I.B (2010) *Panacea to Epileptic Power Supply in Nigeria*. The Pacific Journal of Science and Technology.11, 164-170.
- Alkar, A. Z. and Buhur, U (2005) *An Internet Based Wireless Home Automation System for Multifunctional Devices*. IEEE ConsumerElectronics, 51(4), 1169-1174. Retrieved 6<sup>th</sup> July,
- Delgado, A. R, Picking, R and Grout, V (2006) *Remote-controlled home automation systems with different network technologies*
- Oni, J. O, Abdulsalam, A. O, Tihamiyu, A. K, Lawal, S. A, Okedare, S. D (2015): Design and construction of automatic phase changer. Final year HND project submitted to Kwara State Polytechnic, Ilorin. **PIC16F628 Data sheet** available at <http://www.microchips.com/downloads/en/devicedoc/30292c.pdf> Retrieved 11<sup>th</sup> May, 2016
- Theraja, B. L and Theraja A. K (2005): *A Textbook of Electrical Technology* Vol. 1. New Delhi. S. chand & Co Ltd